

Section 21-07.02 Lighting Regulations.

Intent – The Lighting Regulations contained in this Section are intended to provide for the erection, design, or placement of *outdoor light fixtures* which: provide for illumination levels on individual *lots* which are adequate for the safe and efficient movement of individuals or vehicles to and from a *lot* and within a *lot* (i.e., areas that are dangerous if unlit, such as stairs, intersections or changes in *grade*); are designed to protect against the spillover of light onto abutting properties which may negatively impact occupants of abutting properties; and, are designed to protect against objectionable *glare* onto *public rights-of-way* which may impair the vision of motorists.

(a) **General Requirements.**

All *outdoor light fixtures* on a *lot* shall comply with the following regulations:

- (1) **Applicability** – The Lighting Regulations contained in this Section, unless specifically stated otherwise, are applicable only to any: Residential *District* for a *multifamily project* or any *special exception use*; Commercial / Mixed Use *District*; Industrial *District*; *Planned Unit Development District*; or, special use *district* contained in this Ordinance.
- (2) **Minimum Setback** – Notwithstanding anything in this Ordinance to the contrary for the "Use of *Minimum Yards*" or "Use of *Minimum Yards and Residential Bufferyards*" for any *district*, a freestanding *outdoor light fixture* may be located within a required *front yard, side yard, rear yard, front residential bufferyard, side residential bufferyard* or *rear residential bufferyard*, provided that the freestanding *outdoor light fixture* is located adjacent to the interior edge of such *yard* or *residential bufferyard* and adjacent to a permitted *driveway, parking area, interior access drive, interior access driveway*, or other outdoor use area requiring illumination.
- (3) **Lighting Standards** – *Outdoor light fixtures* shall comply with the standards set forth in Table 21-07.02 - A: Lighting Standards.
- (4) **Mounting of Fixtures (except in Industrial Districts)** – *Full cutoff, cutoff* and *semi-cutoff outdoor light fixtures* shall be mounted parallel to the ground and shall utilize a rigid mounting arm with no built-in uptilt and no adjustment feature.
- (5) **Height of Fixtures** – All *outdoor light fixtures* used to illuminate a particular area on a *lot* (i.e., a *parking area; a loading area; or, an entry way, sidewalk or walkway* areas) shall, within those areas, be of uniform size, design and height.

**Section 21-07.02
Lighting Regulations**

TABLE 21-07.02 - A: LIGHTING STANDARDS			
District	Type of Fixture	Maximum Combined Height of Pole and Base	Maximum Wattage
<i>All Districts</i>	<i>Non Cutoff</i> ⁽¹⁾	20'	100
	<i>Semi Cutoff</i>	30'	400
	<i>Cutoff</i>	35'	400
	<i>Full Cutoff</i>	40'	1,000

⁽¹⁾ *Non-cutoff outdoor light fixtures shall be limited to locations along walkways, driveways, interior access drives, interior access driveways and outdoor seating areas.*

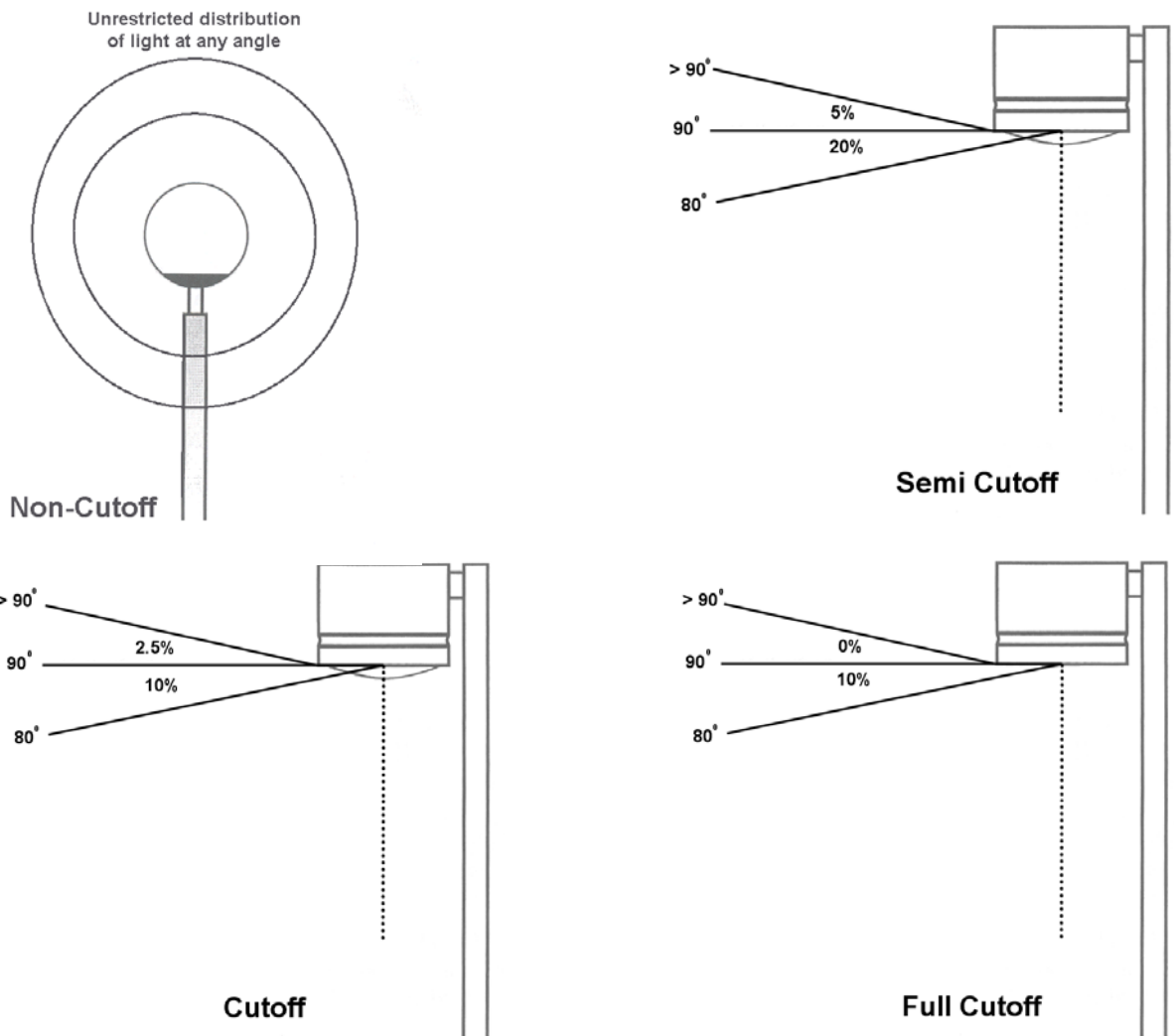

- (6) Power Supply – *Outdoor light fixtures* located on light poles shall be provided power by underground wiring.
- (7) Wall Pack Lights – Wall pack *outdoor light fixtures* shall be subject to the following regulations:
 - (A) Except in Industrial *Districts*, wall pack *outdoor light fixtures* located on a front or side elevations of a *building* or *structure* shall be *full cutoff*.
 - (B) In all Commercial / Mixed Use or Industrial *Districts* – Wall pack *outdoor light fixtures* oriented toward a *residential bufferyard* and an abutting residential *district* shall be *full cutoff*.
 - (C) Low intensity (i.e., 100 watts or less), architectural style wall pack *outdoor light fixtures* (which may be *cutoff*, *semi cutoff* or *non cutoff*) may be used to accent architectural elements of the *building* or *structure* or to illuminate entrance areas.
- (8) *Vehicular Canopy Light Fixtures* – *Outdoor light fixtures* located under a *vehicular canopy* of drive through *structures* (e.g., gasoline service station canopies, bank drive through *canopies*, etc.) shall be *full cutoff* fixtures with a maximum intensity of four hundred (400) watts.
- (9) *Awning and Canopy Lighting* – *Awnings* and *canopies* used for *building* accents over doors, windows, *walkways*, and the like, may be internally illuminated or back-lit (i.e., lit from underneath or behind) provided, however, that the primary material is opaque and that translucent material is limited to the actual text or logo of the *sign*, if any, incorporated into the *awning* or *canopy*.
- (10) *Glare on Public Right-of-Way* – Flag and statue lights, architectural lights, floodlights, or *sign* lighting shall be so directed and shielded that the light element is not visible from any point along an adjacent *public right-of-way*.
- (11) Floodlights – *Outdoor light fixtures* equipped with floodlights may only be permitted on a *lot* as follows:
 - (A) Floodlights shall be focussed on the primary *building* or the area of the *lot* located between the floodlight and the primary *building*; or,
 - (B) Floodlights shall be shielded to the extent that the main beam from the *luminaire* is not visible from or causes any *glare* onto adjacent properties or *rights-of-way*.

Section 21-07.02
Lighting Regulations

(12) Lighting Plans – The following information, at a minimum, shall be provided for all lighting plans submitted in connection with an application for an *improvement location permit*:

- (A) A site plan which includes the outline of *buildings, structures* and other *improvements* (e.g., *parking areas, loading areas, interior access drives, etc.*) on the *lot* and the location of all *outdoor light fixtures*.
- (B) A description of the *outdoor light fixtures*, including but not limited to manufacturers or electric utility catalog specifications sheets, drawings or photometric report, which indicate:
 - i. the *outdoor light fixture* classification (e.g., *cutoff, semi-cutoff, full cutoff, or non-cutoff*);
 - ii. mounting height of freestanding *outdoor light fixtures*; and,
 - iii. wattage proposed for each *outdoor light fixture*.

(b) Special Regulations for Sport and Athletic Field Lights.

Notwithstanding anything in this Section to the contrary, the following special regulations shall apply to Sport and Athletic Field Lights.

Freestanding *outdoor light fixtures* for sport and athletic fields:

- (1) shall not exceed one-hundred and ten (110) feet in height above *grade*; and,
- (2) shall be of a type and manufacturer that offers a spill and *glare* control package and shall be fitted with the manufacturer's spill and *glare* control package.

(c) Exempt Lights.

- (1) Holiday Decorations – *Outdoor light fixtures* used for holiday decorations.
- (2) Public Lighting – All *outdoor light fixtures* originating from public areas and ways, including but not limited to parks, rights-of-way, public art or other public facilities, that are installed for the benefit of the public health, safety and welfare.
- (3) Fossil Fuel Lights – All *outdoor light fixtures* producing light directly from the combustion of fossil fuels (i.e., kerosene lanterns or gas lamps).

- (4) Construction / Emergency Lighting – All *outdoor light fixtures* provided in connection with construction work or the abatement of an emergency situation necessitating said lighting, provided that the use of such *outdoor light fixtures* are discontinued during hours when construction activity or emergency abatement is not in progress and that such *outdoor light fixtures* are removed upon completion of the construction activity or the abatement of the emergency.
- (5) Internal Illumination of Signs – All *outdoor light fixtures* which are completely enclosed within a *sign cabinet* and which provide illumination only for a *sign face*. (See also Section 21-07.03 (g) (6) – Illuminated Signs.)
- (6) *Single Family Dwelling* or *Two Family Dwelling Lots* – All *outdoor light fixtures* used for the illumination of personal property, provided, however, that such *outdoor light fixtures* shall be subject to Section 21-02.11, D., 7., – Performance Standards regarding *glare*.

(d) Temporary Lights.

- (1) Temporary Lights Permitted – The following types of *outdoor light fixtures* may be approved on a temporary basis by the *Zoning Administrator* prior to placement or use.
 - (A) Civic Events – Temporary *outdoor light fixtures* used for civic events.
 - (B) *Special Events* – Temporary *outdoor lighting fixtures* for such activities as circuses, fairs, carnivals, sporting events, and the like.

Such temporary lights shall not be installed more than thirty (30) days prior to the civic event or *special event* and shall be removed not more than fifteen (15) days after the civic event or *special event*.

- (2) Searchlights – Notwithstanding anything contained in Section 21-07.02, (c) – Prohibited Lights of this Ordinance to the contrary, temporary *outdoor light fixtures* used in connection with a civic event or *special event* may include one (1) portable, rotating searchlight provided, however, that such temporary *outdoor light fixture*:
 - (A) shall not be permitted for more than three (3) occurrences during a calendar year;
 - (B) shall not be used for a period of more than two (2) consecutive days during a civic event or *special event*;

Section 21-07.02
Lighting Regulations

(C) shall not be operated between the hours of 12:00 midnight and 8:00 a.m.;
and,

(D) shall otherwise comply with all other applicable provisions of this Section.

(e) Prohibited Lights.

- (1) Flashing Lights – Any lights that flash, move, revolve, rotate, scintillate, blink, flicker, vary in intensity or color, or use intermittent electrical pulsation.
- (2) Floodlights – Floodlights not in compliance with the regulations set forth above, or other form of *outdoor light fixtures* not specifically authorized by this Section (including but not limited to stringer lights), that are ground mounted or attached to light poles, and used to illuminate the site, *buildings* or *structures*.
- (3) Outdoor Strings of Lights – Outdoor strings of lights, including but not limited to those used to outline *lot lines* or *outdoor display* areas, provided, however, outdoor strings of lights may be allowed when complying with Section 21-7.02 (c) (1) – Holiday Decorations.